

NOTES:

1. MATERIAL: HEAVY GAUGE WELDED STEEL
2. FINISH: POWDER COAT ASA 61 GRAY
3. APPROXIMATE UNPACKAGED RACK WEIGHT: 124 LBS.
4. FRAME CONSTRUCTION, BATTERY SUPPORT RAIL DESIGN, AND SEISMIC BRACKET OPTIONS ARE SEISMIC CERTIFIED TO UBC (UNIFORM BUILDING CODE) SECTION 1632.

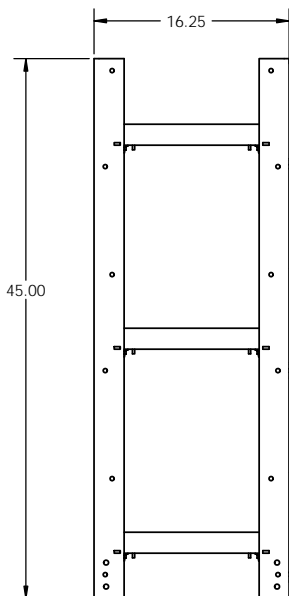

BATTERIES SHOWN FOR REFERENCE ONLY. SOLD SEPARATELY

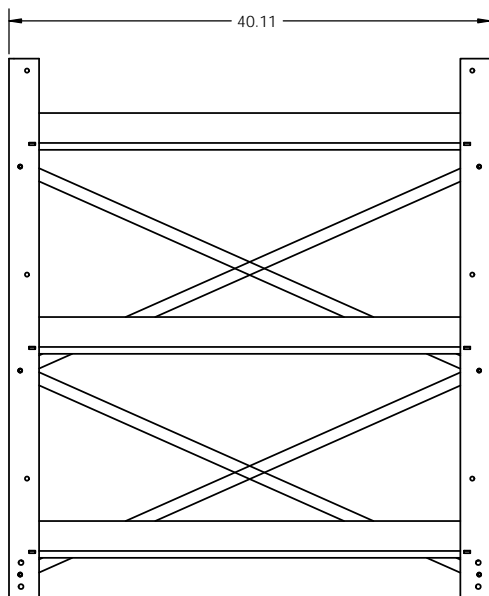
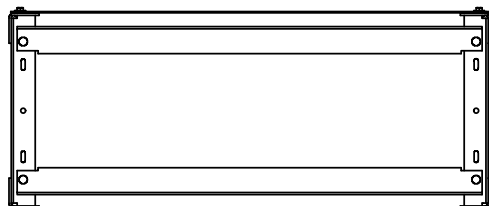
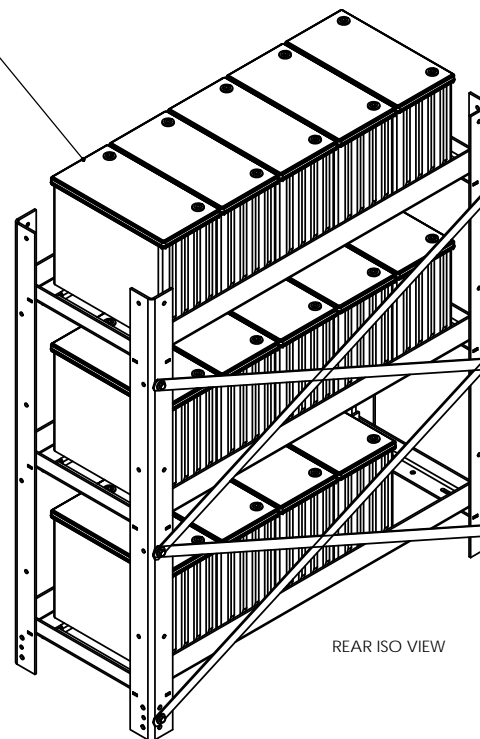

REAR ISO VIEW

MAX BATTERY CAPACITY	
BATTERY TYPE	QTY
100 wpc	21
250 wpc - 800 wpc	15

PROPRIETARY AND CONFIDENTIAL
 THE INFORMATION CONTAINED IN THIS DRAWING IS THE SOLE PROPERTY OF ELECTRONIC SYSTEMS SUPPORT. ANY REPRODUCTION IN PART OR AS A WHOLE WITHOUT THE WRITTEN PERMISSION OF ELECTRONIC SYSTEMS SUPPORT IS PROHIBITED.

UNLESS OTHERWISE SPECIFIED:		ELECTRONIC SYSTEMS SUPPORT 888-475-9292 www.ess.to		3233 W. Kingsley Rd. Ste. 200 Garland, Texas 75041 PH. 972-272-2468 FAX 972-276-9844	
DIMENSIONS ARE IN INCHES		DRAWN: RNA		NAME: RNA	
TOLERANCES:		CHECKED:		DATE: 07-20-09	
ANGULAR: MACH ± .5 BEND #1		MFG APPR:		TITLE: BATTERY RACK, VRLA, 3 TIER/5 WIDE, NON-SEISMIC	
TWO PLACE DECIMAL ± .02		ENG APPR:		SIZE: C	
THREE PLACE DECIMAL ± .01		G.A.:		DWG. NO. R315-SPEC	
PROJECTION:		DO NOT SCALE DRAWING		REV: B	
MATERIAL: SEE NOTE 1		USED ON:		SCALE: 1:8	
FINISH: SEE NOTE 2				WEIGHT:	
				SHEET 1 OF 1	