

NOTES:

1. MATERIAL: HEAVY GAUGE WELDED STEEL
2. FINISH: POWDER COAT ASA 61 GRAY
3. APPROXIMATE UNPACKAGED RACK WEIGHT: 89 LBS.
4. FRAME CONSTRUCTION, BATTERY SUPPORT RAIL DESIGN, AND SEISMIC BRACKET OPTIONS ARE SEISMIC CERTIFIED TO UBC (UNIFORM BUILDING CODE) SECTION 1632.

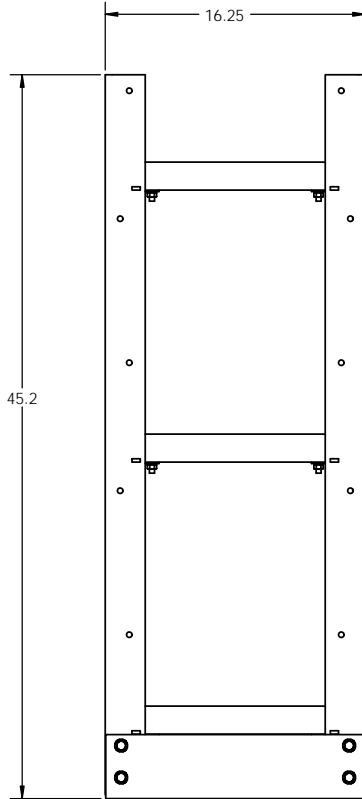

BATTERIES SHOWN FOR REFERENCE ONLY, SOLD SEPARATELY

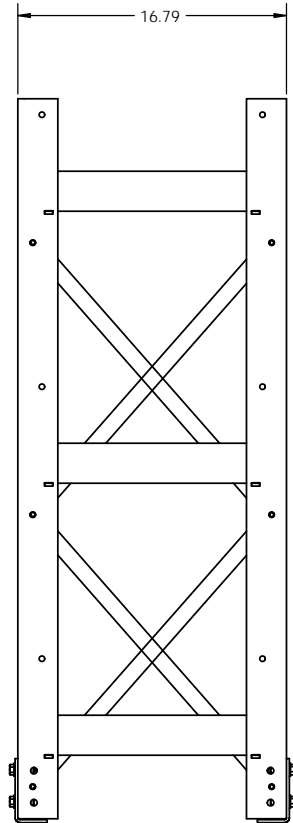
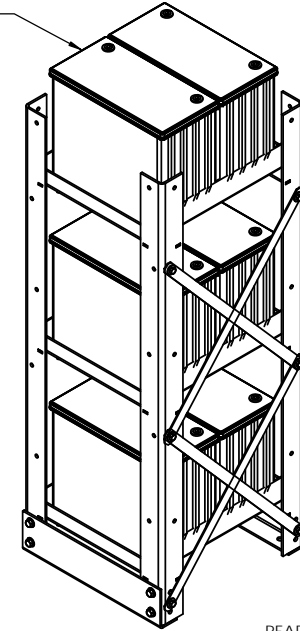

REAR ISO VIEW

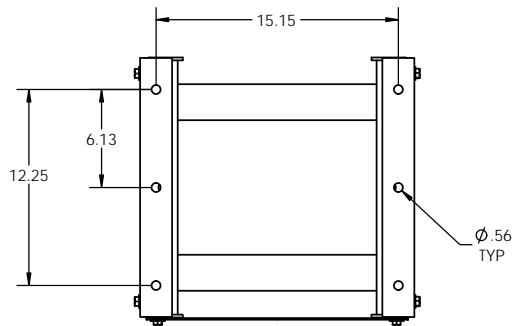

BOTTOM VIEW
OPTIONAL SEISMIC MOUNTING FOOTPRINT

MAX BATTERY CAPACITY	
BATTERY TYPE	QTY
100 wpc	9
250 wpc - 800 wpc	6

PROPRIETARY AND CONFIDENTIAL
THE INFORMATION CONTAINED IN THIS DRAWING IS THE SOLE PROPERTY OF ELECTRONIC SYSTEMS SUPPORT. ANY REPRODUCTION IN PART OR AS A WHOLE WITHOUT THE WRITTEN PERMISSION OF ELECTRONIC SYSTEMS SUPPORT IS PROHIBITED.

UNLESS OTHERWISE SPECIFIED: DIMENSIONS ARE IN INCHES TOLERANCES: ANGULAR: MACH ± .5 BEND ±1 TWO PLACE DECIMAL ± .02 THREE PLACE DECIMAL ± .01	ELECTRONIC SYSTEM SUPPORT 888-475-9292 www.ess.to			3233 W. Kingsley Rd. Ste. 200 Garland, Texas 75041 PH. 972-272-2468 FAX 972-276-9844		
	DRAWN: RNA CHECKED: [] ENG APPR: [] MFG APPR: [] Q.A. []	NAME: [] DATE: 07-20-09	TITLE: BATTERY RACK, VRLA, 3 TIER/2 WIDE, SEISMIC Z4			
PROJECTION:	SEE NOTE 1	SEE NOTE 2	USED ON	SIZE: C	DWG. NO.: R3T2Z4-SPEC	REV: B
DO NOT SCALE DRAWING			SCALE: 1:8	WEIGHT:	SHEET 1 OF 1	