

NOTES:

1. MATERIAL: HEAVY GAUGE WELDED STEEL
2. FINISH: POWDER COAT ASA 61 GRAY
3. APPROXIMATE UNPACKAGED RACK WEIGHT: 70 LBS.
4. FRAME CONSTRUCTION, BATTERY SUPPORT RAIL DESIGN, AND SEISMIC BRACKET OPTIONS ARE SEISMIC CERTIFIED TO UBC (UNIFORM BUILDING CODE) SECTION 1632.

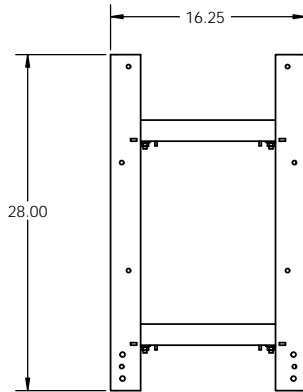

BATTERIES SHOWN FOR REFERENCE ONLY. SOLD SEPARATELY

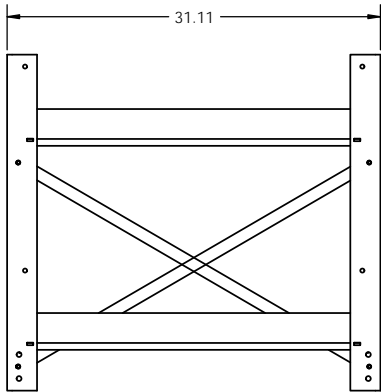
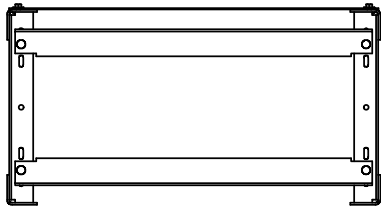
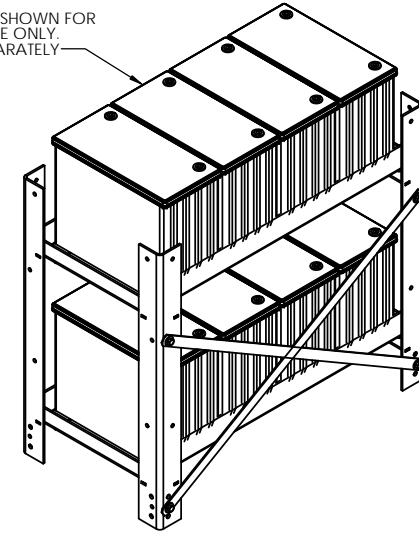

REAR ISO VIEW

MAX BATTERY CAPACITY	
BATTERY TYPE	QTY
100 wpc	10
250 wpc - 800 wpc	8

PROPRIETARY AND CONFIDENTIAL
THE INFORMATION CONTAINED IN THIS DRAWING IS THE SOLE PROPERTY OF ELECTRONIC SYSTEMS SUPPORT. ANY REPRODUCTION IN PART OR AS A WHOLE WITHOUT THE WRITTEN PERMISSION OF ELECTRONIC SYSTEMS SUPPORT IS PROHIBITED.

UNLESS OTHERWISE SPECIFIED:		ELECTRONIC SYSTEMS SUPPORT 888-475-9292 www.ess.to		3233 W. Kingsley Rd. Ste. 200 Garland, Texas 75041 PH. 972-272-2468 FAX 972-276-9844	
DIMENSIONS ARE IN INCHES TOLERANCES:		DRAWN	NAME	DATE	TITLE
ANGULAR: MACH ± .5 BEND ±1		RNA	RNA	07-20-09	BATTERY RACK, VRLA, 2 TIER/4 WIDE, NON-SEISMIC
TWO PLACE DECIMAL ± .02		CHECKED			SIZE
THREE PLACE DECIMAL ± .01		ENG APPR			DWG. NO.
PROJECTION		MFG APPR			REV
MATERIAL	SEE NOTE 1	Q.A.			B
FINISH	SEE NOTE 2				SCALE: 1:8
USED ON	DO NOT SCALE DRAWING				WEIGHT:
					SHEET 1 OF 1