

NOTES:

1. MATERIAL:
FEET: 7 GA HRPO
RACK FRAME: 10 GA HRPO
2. FINISH: POWDER COAT NID GRAY (ADD -BLK AFTER P/N TO ORDER IN RAVEN BLACK)
3. APPROXIMATE (UNPACKAGED) WEIGHT: 30.8 KG

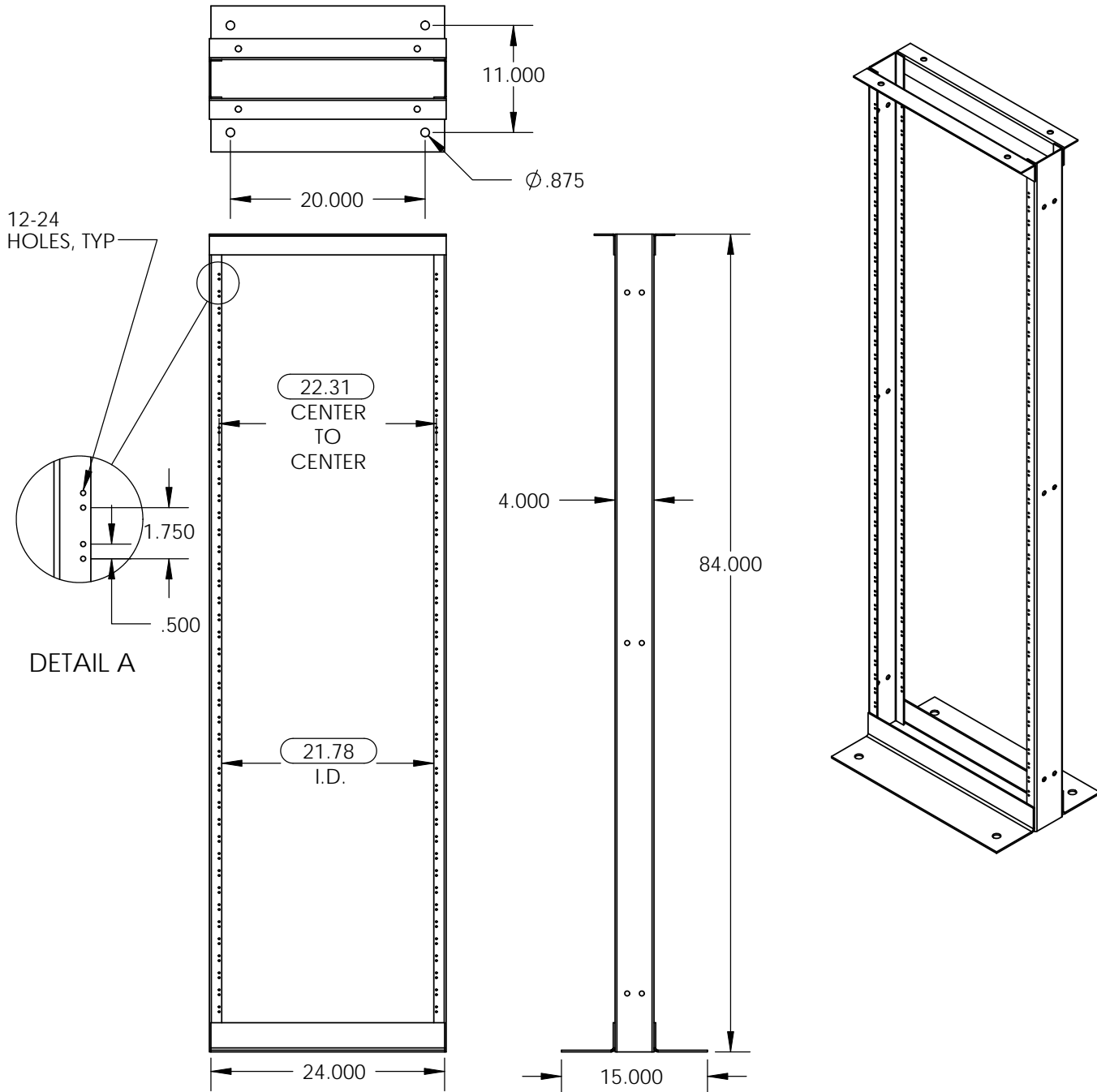

PROPRIETARY AND CONFIDENTIAL
THE INFORMATION CONTAINED IN THIS
DRAWING IS THE SOLE PROPERTY OF
ELECTRONIC SYSTEMS SUPPORT. ANY
REPRODUCTION IN PART OR AS A WHOLE
WITHOUT THE WRITTEN PERMISSION OF
ELECTRONIC SYSTEMS SUPPORT IS
PROHIBITED.

USED ON

UNLESS OTHERWISE SPECIFIED:

DIMENSIONS ARE IN INCHES
TOLERANCES:

ANGULAR: MACH $\pm .5$ BEND ± 1
TWO PLACE DECIMAL $\pm .01$
THREE PLACE DECIMAL $\pm .005$

PROJECTION:

MATERIAL
SEE NOTE 1

FINISH
SEE NOTE 2

DO NOT SCALE DRAWING



ELECTRONIC SYSTEM SUPPORT
888-475-9292 www.ess.to

110 AUSTIN STREET
GARLAND, TX 75040
PH. 972-272-2468
FAX 972-276-9844

	NAME	DATE
DRAWN	RNA	9-20-10
CHECKED		
ENG APPR.		
MFG APPR.		
Q.A.		

TITLE: EQUIPMENT RACK, 23", 84" TALL 4" CHANNEL, HD		
SIZE	DWG. NO.	REV
B	EQR2308404-A-SPEC	A
SCALE: 1:24	WEIGHT:	SHEET 1 OF 1