

SECTION A-A
BOTTOM VIEW

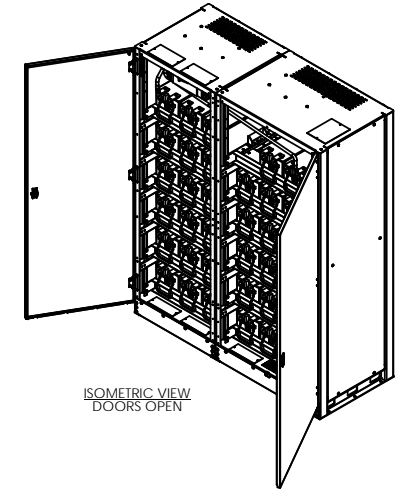

ISOMETRIC VIEW
DOORS OPEN

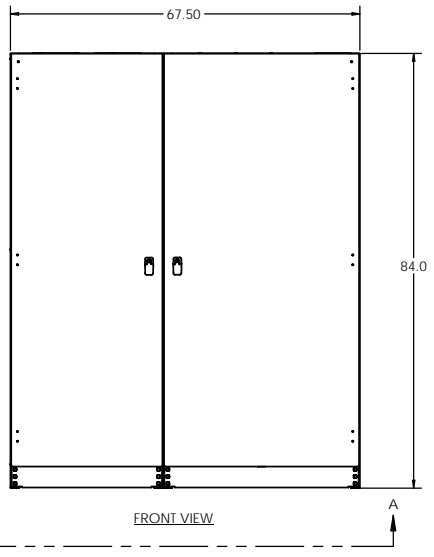

FRONT VIEW

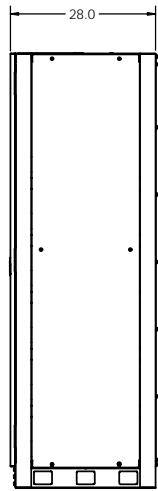

SIDE VIEW

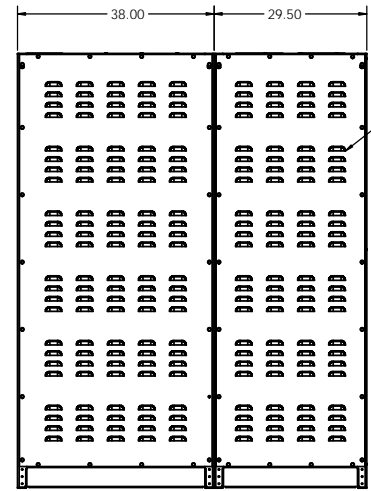

REAR VIEW

VENTILATION
LOUVERS

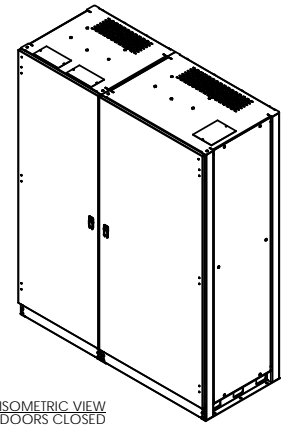

ISOMETRIC VIEW
DOORS CLOSED

CABINET NOTES:

1. NEMA 1 DESIGN.
2. EMPTY CABINET WEIGHT: 1070 LBS (486.4 KG) TOTAL FOR 2 CABINETS FOR 480V STRING
3. UL 1778 LISTED AND FULLY TESTED AT THE FACTORY PRIOR TO SHIPPING.
4. FULLY WELDED FRAME, MANUFACTURED FROM HEAVY GAUGE STEEL
5. POWDER COATED WITH A CORROSION RESISTANT, EPOXY HYBRID POWDER USING A FIVE STAGE EMERSION PRETREATMENT PROCESS.
6. BATTERIES CAN BE ACCESSED FROM FRONT, REAR, AND BOTH SIDES.
7. CUSTOM DESIGNED PALLETS FOR SHIPPING ANYWHERE LOCALLY AND GLOBALLY (UPON REQUEST)
8. BATTERY CABINET CAN BE MOVED WITH A NORMAL PALLET JACK FROM FRONT AND REAR.
9. STANDARD AND CUSTOM SPILL CONTAINMENT OPTIONS ARE AVAILABLE.

<small>PROPRIETARY AND CONFIDENTIAL SEE REVISIONS CONTROLLED IN THE DRAWINGS IN THE CASE OF DISCREPANCY ELECTRONIC SYSTEMS SUPPORT HAS INDICATED THE DRAWING IS AN UNCONTROLLED REVISION OF THE ORIGINAL DRAWING. ELECTRONIC SYSTEMS SUPPORT IS NOT RESPONSIBLE FOR THE CONTENTS OF THIS DRAWING.</small>	UNLESS OTHERWISE SPECIFIED DIMENSIONS ARE IN INCHES TOLERANCES: FRACTIONS: MACH ± .010 DECIMALS: .01 HOLE PUNCH DIMENSIONS: .015	ESS ELECTRONIC SYSTEMS SUPPORT 888-475-9292 www.ess.io		3233 W. Kingsley Rd. Ste. 200 Garland, Texas 75041 PH: 972-272-2468 FAX: 972-276-9844	
	DATE: 12-28-12	ISSUED:	TITLE:	BATTERY CABINET, 12V FT.	
	DESIGNED BY: [signature]	CHECKED BY: [signature]	SIZE:	DWG. NO.	REV.
	PROJECT: SEE NOTE 1	DATE:	SCALE:	EFC63-SPEC	B
	USED ON:	SCALE: 1:12	WEIGHT:	SHEET 1 OF 2	

BREAKER DETAIL

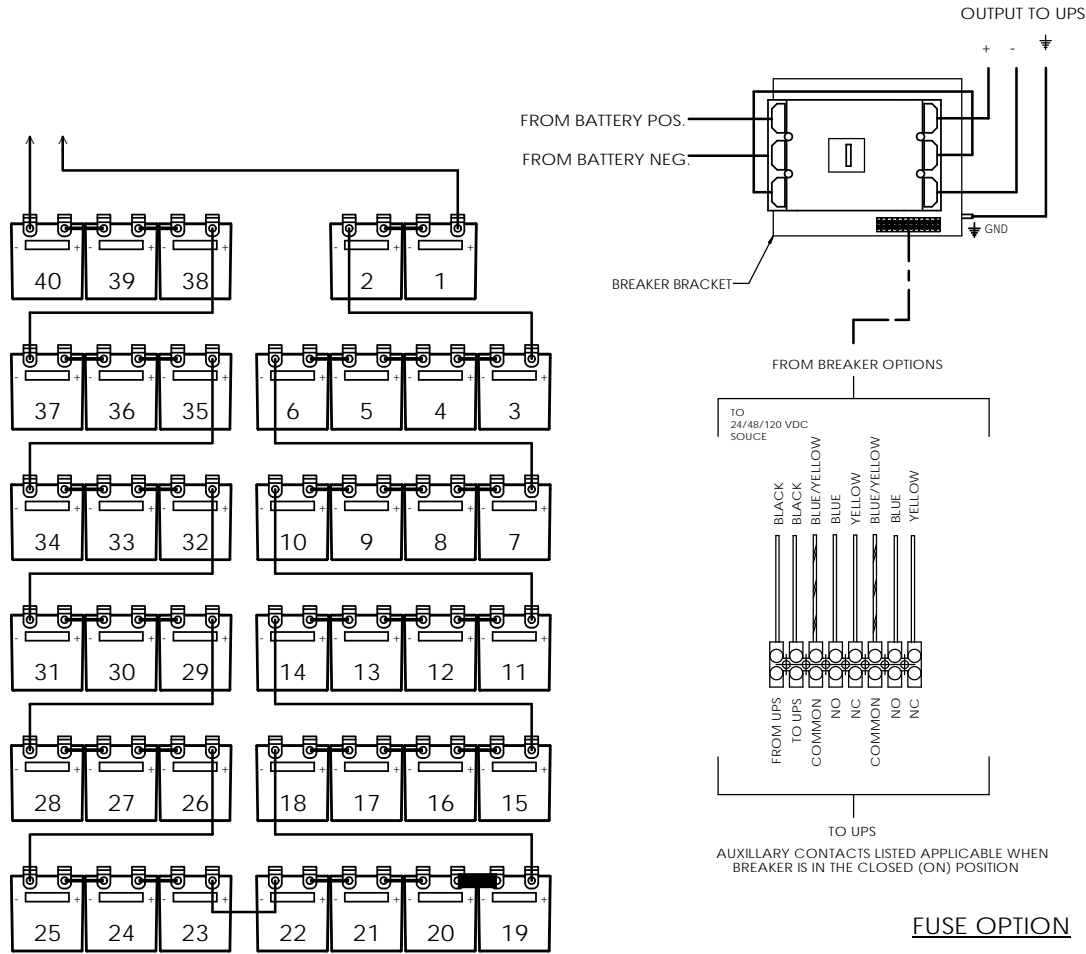

BATTERY CABINET PART NUMBER GUIDE			
CABINET PART NUMBER			DESCRIPTION
EFC63	A	A	
BASE PART NUMBER			
CABINET HEIGHT			
CABINET COLOR			

BATTERY MODEL NUMBER	BATTERY MANUFACTURER				MAXIMUM NUMBER OF BATTERIES PER CABINET
	ENERSYS	C & D	EAST PENN	INTERSTATE	
12HX680	UPS12-745MRF	4DHR6500	12MJ4500F		40

HEIGHT LEGEND	
HEIGHT (INCHES)	AVAILABILITY
**A = 84.00	IN STOCK
B = 82.00	N/A
C = 80.00	N/A
D = 79.0	N/A
E = 78.7	N/A
F = 78.4	N/A
G = 78.0	N/A
H = 77.3	N/A
J = 76.8	N/A
K = 75.3	N/A
L = 75.0	N/A
M = 74.8	N/A
N = 73.5	N/A
P = 72.0	N/A
Q = 71.7	N/A
R = 70.9	N/A
S = TBD	N/A
T = TBD	N/A

** 84.0 IS THE STANDARD HEIGHT FOR THE EFC63 CABINETS. SHORTER HEIGHTS ARE NOT AVAILABLE** PLEASE CONSULT WITH SALES STAFF FOR FURTHER INFO.

COLOR LEGEND	
**A = BLACK	
B = BEIGE	
C = LIEBERT GRAY	
D = MITSUBISHI BEIGE	
E = MGE WHITE	
F = TOSHIBA BLACK	
G = GE WHITE	
H = LIEBERT BLACK	
J = EATON BLACK	
K = TBD	

BLACK IS ESS STANDARD COLOR AND WILL BE IN STOCK
LETTERS STATING "TBD" ARE OPEN FOR CUSTOM COLORS NOT LISTED. PLEASE CONSULT WITH SALES STAFF FOR FURTHER INFO.

FUSE OPTION

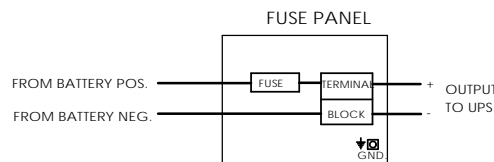

ELECTRICAL NOTES:

1. ALL CABLES ARE UL LISTED.
2. ALL BREAKERS ARE UL RECOGNIZED.
3. ALL FUSES ARE UL RECOGNIZED, TYPE A50P, A70P OR EQUIVALENT (FUSED CABINETS ARE NOT LISTED IN UL FILE). ALWAYS REPLACE WITH SAME TYPE OR ITS EQUIVALENT.
4. TERMINAL BLOCKS ARE UL RECOGNIZED, 600V RATED.
5. CABINETS ARE SHIPPED WITH THE BREAKER IN THE TRIPPED POSITION.
6. CABINET GROUND CONNECTION IS A 5/16-18 THREADED STUD.
7. CABLES BETWEEN BATTERY CABINET TO UNINTERRUPTIBLE POWER SUPPLY ARE OPTIONAL.

PART NUMBER GUIDE:

1. REFERENCE THE BATTERY PART NUMBER GUIDE TABLE WHEN ORDERING A CABINET.
2. THE BASE NUMBER WILL ALWAYS BE THE SAME. HOWEVER, 2 ALPHA DIGITS WILL FOLLOW THE BASE NUMBER INDICATING THE HEIGHT AND COLOR OF THE CABINET.
3. REFERENCE THE "HEIGHT LEGEND" TABLE AND THE "COLOR LEGEND" TABLE IN ORDER TO DETERMINE THE 2 ALPHA DIGITS NEEDED TO COMPLETE YOUR ORDER.
4. EXAMPLE: EFC63AA - THIS REPRESENTS A STANDARD EFC63 CABINET, 84.0 INCH HEIGHT WITH A POWDER COAT FINISH OF STANDARD BLACK.
5. THE EFC63 CABINET IS NOT AVAILABLE IN OTHER HEIGHTS OTHER THAN 84.0 INCHES.

UNLESS OTHERWISE SPECIFIED DIMENSIONS ARE IN INCHES		ELECTRONIC SYSTEM SUPPORT 888-475-9292 www.ess.io		3233 W. Kingsley Rd. Ste. 200 Cedarland, Texas 75041 PH: 972-272-2468 FAX: 972-272-1844	
PROPRIETARY AND CONFIDENTIAL	SEE NOTE 1	DATE	2-28-12	TITLE	BATTERY CABINET, 12V FT. 4D BATTERY, 6 TIER
DESIGNED BY	ISS	DATE		SIZE	DWG. NO.
CHECKED BY	ISS	DATE		SCALE	EFC63-SPEC
APPROVED BY	ISS	DATE		REV	B
USED ON	SEE NOTE 2	DATE		SCALE: 1:12	WEIGHT: SHEET 2 OF 2